

229A - Piper

(Supersedes Service Bulletin No. 229)
(Piper Considers Compliance Mandatory)

Piper Aircraft Corporation
Lock Haven, Pennsylvania, U.S.A.

Date:
June 17, 1966

SUBJECT:
Removal of Restriction to Airspeed Limits

MODELS AFFECTED:
PA-30 Twin Comanche, Serial Nos. 30-853, 30-902 to 30-1159 incl.

COMPLIANCE DATE:
Prior to but not later than next 10 hours of operation after receiving Stabilator Balance Weight Kit 757 044

Owners and operators of the subject aircraft were advised recently that because vibration has been observed at approximately the red line not-to-exceed limit, it was necessary to restrict the airspeed to 218 MPH.

It has been determined that the installation of balance weights, part numbers 25780-02 and 25780-03 in addition to the standard balance weight, part number 23594-00, will eliminate this vibration, however, the original never-exceed airspeed limit, 245 MPH, must be reduced to 240 MPH.

NOTE
The Airspeed Indicator Placard SK-1814 contained in Kit 747 044 must not be installed on aircraft equipped with Brittain Industries Tip Tanks model No. TT-5 since these aircraft are restricted to a 230 MPH never-to-exceed speed limit. However, the balance of the requirements contained in this bulletin remain effective.

A placard for the airspeed indicator, a revised Flight Manual, Stabilator Balance Weights and an AN4-36A bolt are contained in Kit 757 044. Information concerning the installation of this kit is contained on sketch "A" below this bulletin.

It will be necessary to rebalance the stabilator before or after Kit 757 044 is installed, provided that during the service life of the airplane no alterations or repairs were made to the stabilator, the stabilator trim tab or the balance weight installation.

If alterations or repairs to the stabilator installation were made, the stabilator must be rebalanced in accordance with the balancing instructions and sketch "B" below this bulletin prior to the installation of Kit 757 044.

Compliance with this Service Bulletin will eliminate the requirements of the F.A.A. Airworthiness Directive No. 66-12-2 issued May 3, 1966, amended May 20, 1966. The placard restricting the airspeed to 218 MPH must be removed and the new placard contained in the subject kit must be installed. The Flight Manual must be replaced with the new Flight Manual, Piper Report No. 1269, revised June 8, 1966. Retain the supplements to the Flight Manual and destroy the old basic Flight Manual.

The additional weight as a result of this bulletin is negligible, therefore, no change is required in the Weight and Balance Form.

NOTE
If balancing of the stabilator is required in the future, balance weights 25780-02 and 25780-03 and the AN4-36A bolt contained in Kit 757 044 must be removed. Balancing shall then be accomplished in accordance with the attached balancing instructions and sketch "B". Kit 757 044 must be reinstalled after balancing is completed. The balancing information contained herein shall become a part of the PA-30 Twin Comanche Service Manual on a revision to be issued in the near future.

"DISTRIBUTORS"
Distributors should estimate their requirements for Kit 757 044 and submit their orders to the Service Spares Department, Piper Aircraft Corporation, Lock Haven, Pennsylvania.

A Warranty and Credit Claim may be submitted for Kit 757 044.

Credit will not be issued for Kit 757 044 on any claims received after November 30, 1966.

SKETCH A

SKETCH A

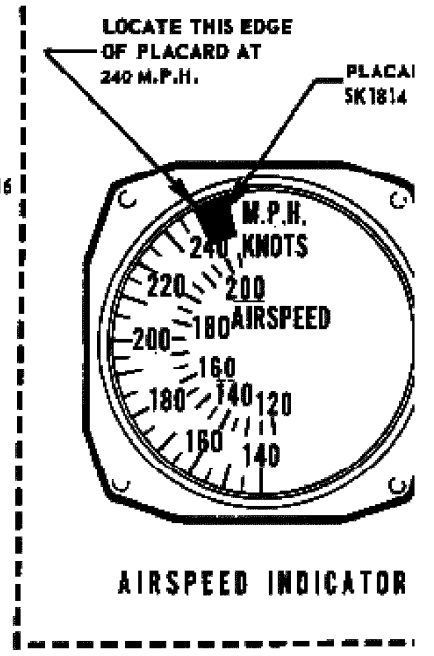
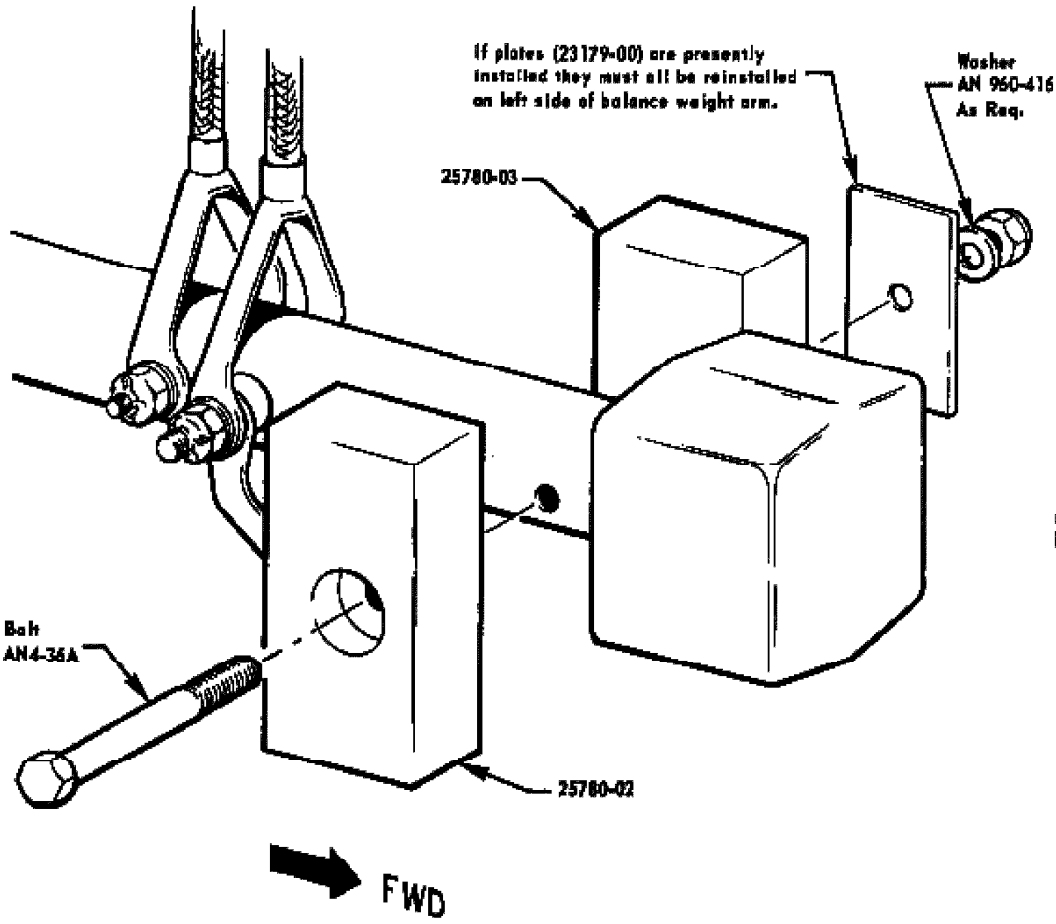

SKETCH B

SKETCH B

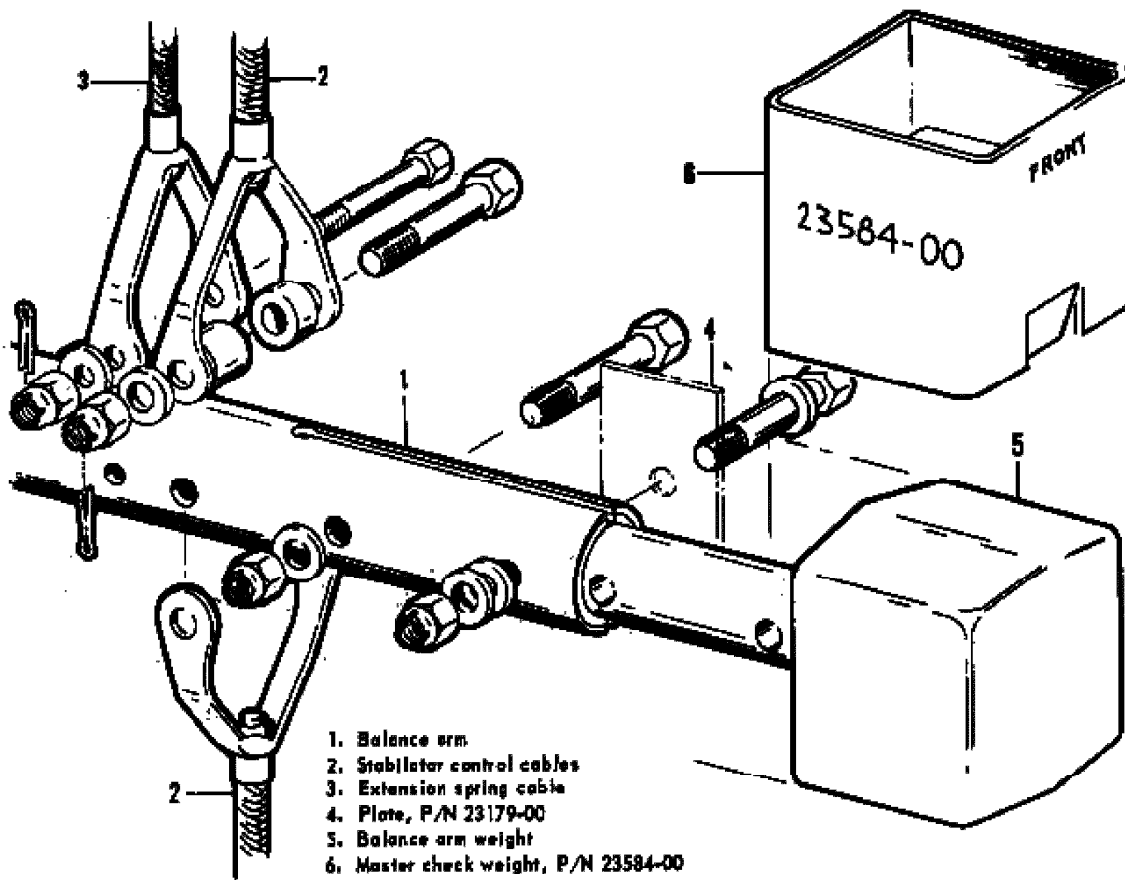

MODEL PA-30 SERIAL NOS. 30-853, 30-902 AND UP PROCEDURE FOR BALANCING THE STABILATOR

a. Whenever a stabilator has been repaired, it must be balanced before being flown.

b. Stabilator installation must be complete before balancing, including tabs and paint. Stabilator control cables must be disconnected from stabilator balance arm and tab actuator arm must be disconnected from stabilator tab horn during balancing. Hardware used to connect the extension spring cable and stabilator control cables should be removed. Forward AN4-16A bolt, washer and nut holding balance arm weight in place should be installed. A small piece of tape should be used to hold tabs neutral with stabilator. It is very important to have the stabilator free to rotate with a minimum of frictional resistance.

NOTE

If the bearing resistance is more than light, the nuts of the bolts holding the stabilator torque horn to the stabilator torque tube, the nuts of the bolts holding the stabilator to the torque tube and the nuts of the bolts holding the stabilator stop to the torque tube should be loosened and the bearing resistance measured again. When this done, the nuts must be tightened just enough to take the play out of the washers. The bolts holding the stabilator bearing blocks to the fuselage shall be loosened and tightened finger tight during balancing. After balancing is completed, stabilator bearing block bolts shall be torqued to a value of 135-140 inch lbs. Ascertain that the stabilator is free to rotate with minimum friction.

c. Master check weight 23584-00 (weight 1.58 pounds) should be placed on top of balance weight 23594-00 with side marked "FRONT" facing forward. If this is not enough weight to obtain static balance with the balance arm level, plates 23179-00 must be added to the forward balance weight attachment bolt until 100% static balance is obtained or until up to two plates more than that required for balance have been added. It should never be necessary to use more than eight plates. If a total of more than eight plates are necessary to obtain balance, the manufacturer should be consulted.

d. If it should become necessary in the field to balance a stabilator without a master check weight, a temporary balancing can be accomplished by following the procedure given in "b" above except that instead of using a master check weight a sensitive and accurate spring scale can be used to get a balance with 49 ± 0.3 inches pounds of torque. Thus plates should be added (up to eight) until a lifting force of between 2.71 and 2.88 pounds will balance the stabilator with the spring scale being hooked to the bolt which fastens the two stabilator-connecting tabs together (arm of 17 inches). As soon as a master check weight is available the balance should be checked for accuracy.

e. After balancing is accomplished, the check weight should be removed and the front attachment bolt connecting the stabilator balance weight to the stabilator balance arm shall be removed and weights, part nos. 25780-02, 25780-03 and bolt AN4-36A and stabilator balance weight plates 23179-00 shall be installed at this attachment point. Stabilator balance weight, part no. 25780-02 shall be installed on the right side of the stabilator balance arm and stabilator balance weight, part no. 25780-03 and stabilator balance weight plates 23179-00 shall be installed on the left side of the stabilator balance arm.

NOTE

Balance weight, part no. 25780-02 shall be installed such that the counterbore and bolt head face outboard on the right side of the balance arm.

f. All stabilator and tab controls should be reconnected.

g. The stabilator control extension spring link should be adjusted to obtain 1-1/4 inch extension of the spring with the stabilator stops adjusted and the control wheel in the full forward position.

h. The operation and feel of the stabilator controls should then be checked for proper movement.

