



SERVICE LETTER

No. 05

Piper Aircraft Corporation

Lock Haven, Pennsylvania, U.S.A.

October 1, 1958

TO: All Distributors, Dealers, Owners and Operators
MODEL AFFECTED: PA-24 Comanche, Serial Numbers Listed Below

SERIALS 24-1 TO 24-336 INCLUSIVE

1. The main cabin door latch has been modified to provide a positive means of opening the door from the inside when it has been locked from the outside. We suggest that your door be revised as follows. Remove door latch assembly by loosening door trim upholstery and removing screws attaching latch plate and latch assembly to door frame. Disconnect latch pull rod from inside door handle and remove complete latch assembly. Modify latch assembly per Sketch "A" below this letter and install a new part number 21826.

SERIALS 24-1 TO 24-351 INCLUSIVE (PA-24 "250" ONLY)

2. Rotate oil separator and install new hose part number 82371-17 and hose adapter part number 451 861 (AN840-9D) per Sketch "B" below this letter.

SERIALS 24-1 TO 24-268 INCLUSIVE

3. The landing gear retraction transmission cover casting has been redesigned to give greater strength. We recommend that the old castings be removed and a new kit 754 204 be installed.

SERIALS 24-1 TO 24-333 INCLUSIVE

4. To prevent interference between the landing gear retraction tube arms and the retraction tube rod end bearings, the arms shall be modified per Sketch "C" below this letter.

SERIALS 24-1 TO 24-414 INCLUSIVE

5. New plastic tubing with low temperature flexibility shall replace the present plastic tubing on the main gear electrical harness assemblies. These harness assemblies are located directly inside their respective landing gear wheel well openings. Remove wing butt bottom fairings and disconnect harnesses before loosening gear harnesses from their retaining grommets and clamps. (NOTE: The plastic tube on the inboard end of the left gear harness does not need to be replaced.) Thirty (30) inches of part number 189 571 is required for the right gear harness and seventeen and one-half (17-1/2) inches of part number 189 571 and forty five (45) inches of part number 189 568 are required for the left gear harness. To preclude the possibility of water collecting inside the nose gear harness and the generator harness plastic tubes, a 1/8" drain hole shall be punched in the plastic tube at the low points of each harness assembly.

Material for items 1, 2, 3 and 5 can be obtained from your nearest Piper distributor free of charge until May 1, 1959. To secure this material free of charge it will be necessary that the aircraft serial number or numbers be included on all purchase orders.

Warranty labor of eight (8) hours will be granted upon receipt of Warranty Claim Form.

Very truly yours,

PIPER AIRCRAFT CORPORATION

A handwritten signature in cursive script, appearing to read "R Boardman".

Rolland Boardman
Service Manager

RB:mh

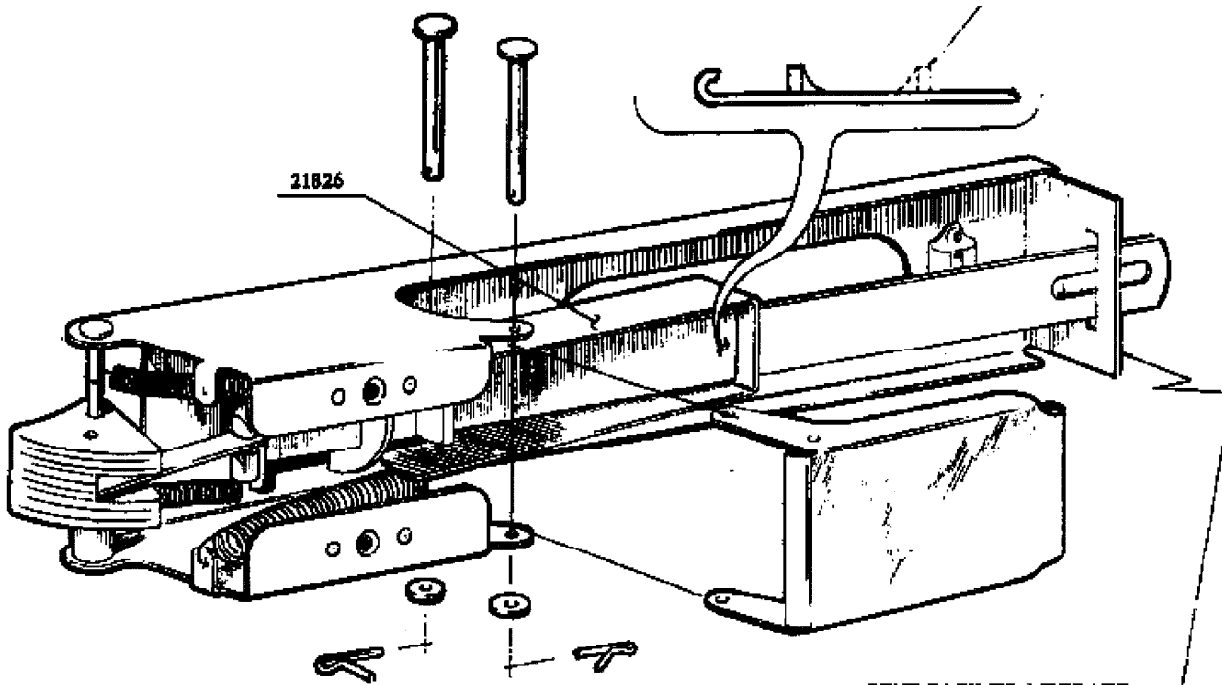

BEND BACK TO LIBERATE
END OF ACTUATING PLATE
TO INSTALL PART NO. 21826

DOOR LATCH MODIFICATION	
SKETCH "A"	S. L. #305
PIPER AIRCRAFT CORPORATION	
LOCK HAVEN, PENNSYLVANIA	

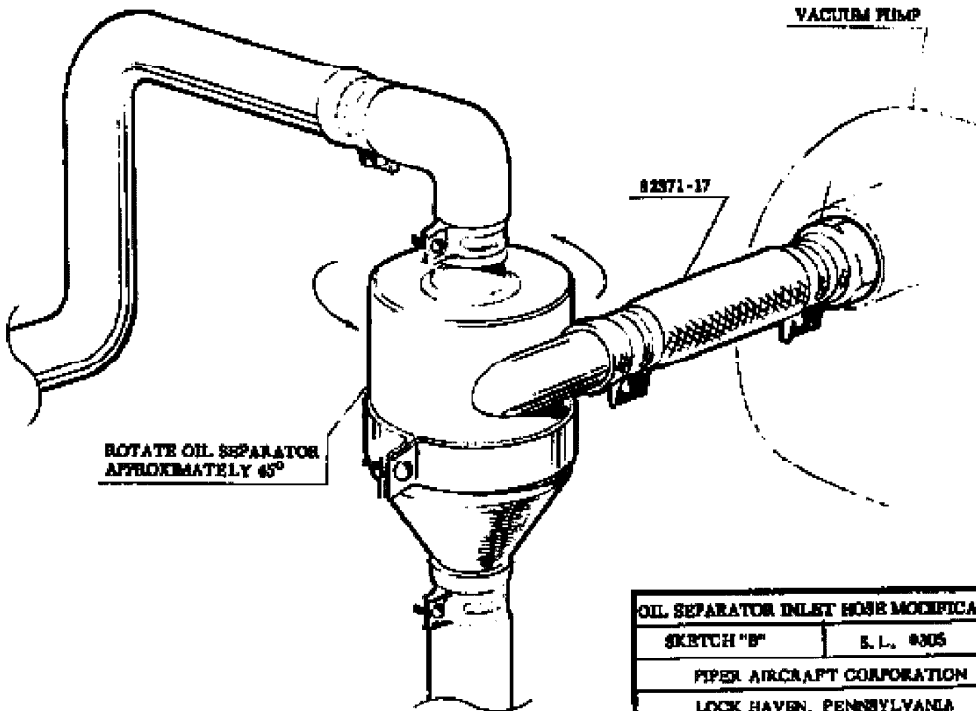

ROTATE OIL SEPARATOR
APPROXIMATELY 45°

OIL SEPARATOR INLET HOSE MODIFICATION	
SKETCH "B"	S. L. #305
PIPER AIRCRAFT CORPORATION	
LOCK HAVEN, PENNSYLVANIA	

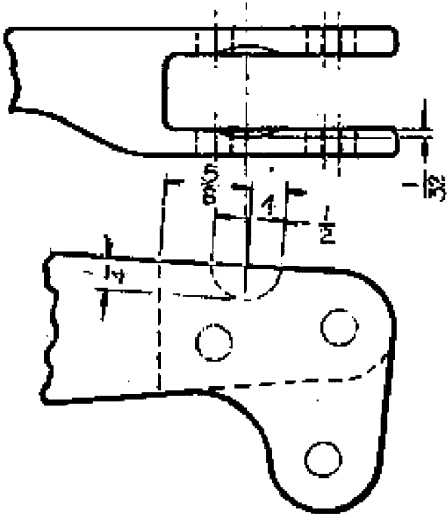
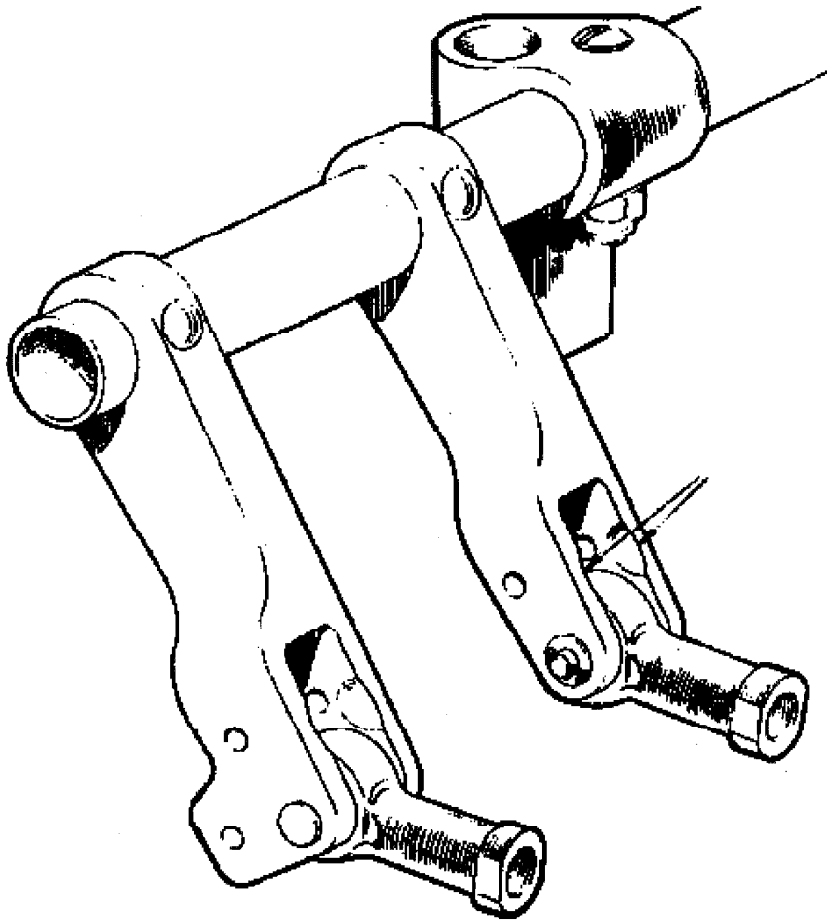

L. G. Retraction Tube Arms Modification	
SKETCH "C"	S. L. #305
PIPER AIRCRAFT CORPORATION	
LOCK HAVEN, PENNSYLVANIA	