

## 777 - Piper

Piper Aircraft Corporation  
Lock Haven, Pennsylvania, U.S.A.

**Date:**

June 16, 1976

**SUBJECT:**

Fin Front Spar Modification.

**MODELS AFFECTED:**

PA-30 Twin Comanche  
PA-39 Twin Comanche "C/R"

**SERIAL NUMBERS AFFECTED:**

30-1 to 30-2000 Inclusive  
39-1 to 38-155 Inclusive.

**COMPLIANCE TIME:**

At the owners/operators discretion.

**PURPOSE:**

FAA Airworthiness Directives #75-12-06 dated June 5, 1976 required a repetitive inspection of the PA-24 Comanche series Fin Front Spar to Fuselage Attachment Channel bend relief holes for evidence of cracks; repair or replace cracked channels/ straps if cracks are detected . . . etc. We have been advised that, in the near future, the FAA is planning a similar action relative to the PA-30 and PA-39 Twin Comanche series.

Since it is necessary to physically remove the Fin Assembly to gain visual access to the channel relief holes (as the Fin Front Spar extends over the relief holes diameter), this service release provides instructions to modify the Fin Front Spar to eliminate repetitive removal of the fin and to enable an easy visual inspection.

**INSTRUCTIONS:**

Refer to "Spar Trimming Detail" Instructions on reverse side of this service release.

**MATERIAL REQUIRED:**

Not Applicable.

**AVAILABILITY OF PARTS:**

Not Applicable.

**EFFECTIVITY DATE:**

This service release is effective upon receipt.

**SUMMARY:**

Please contact your Piper Field Service Facility to make arrangements for this modification which will simplify access to and visual inspection of the Fin lower Front Spar area.

FIGURE 1

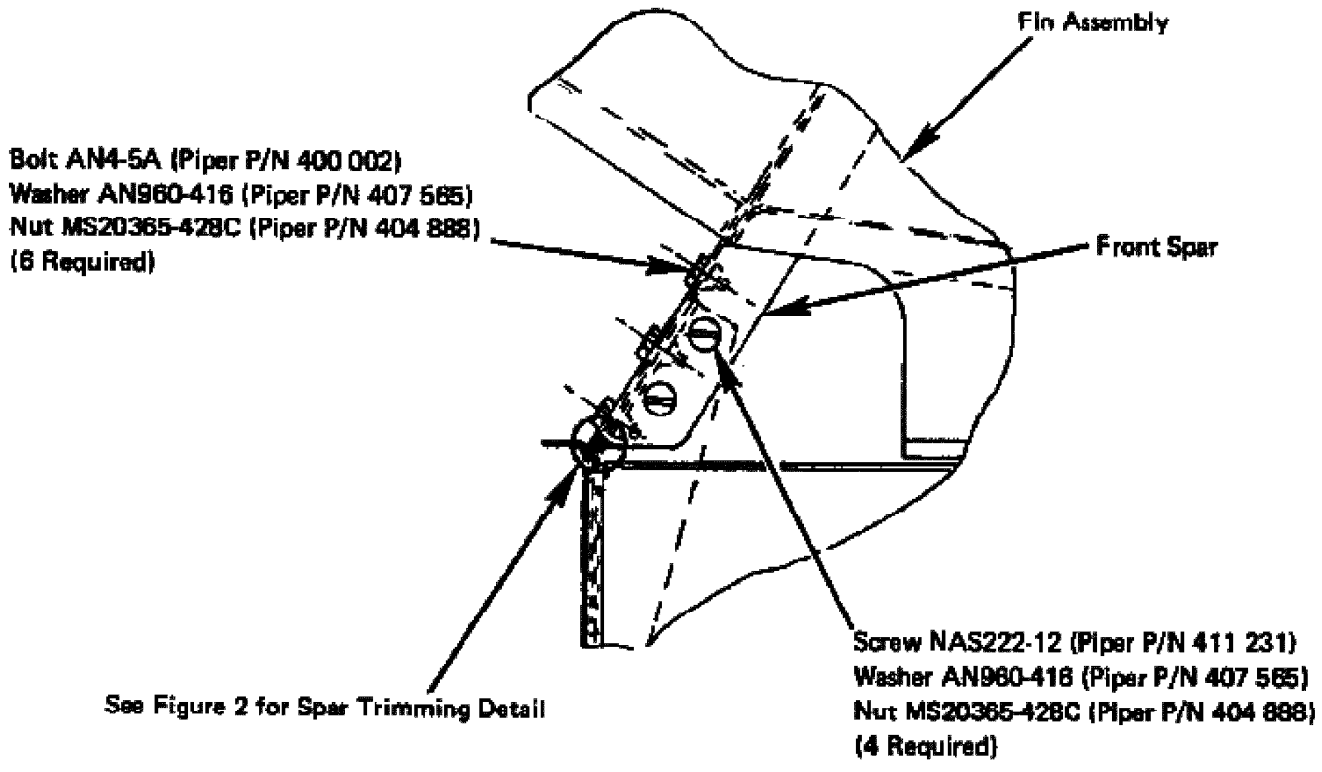

**FIGURE 1**

**(FIN FRONT SPAR ATTACHMENT)**

FIGURE 2

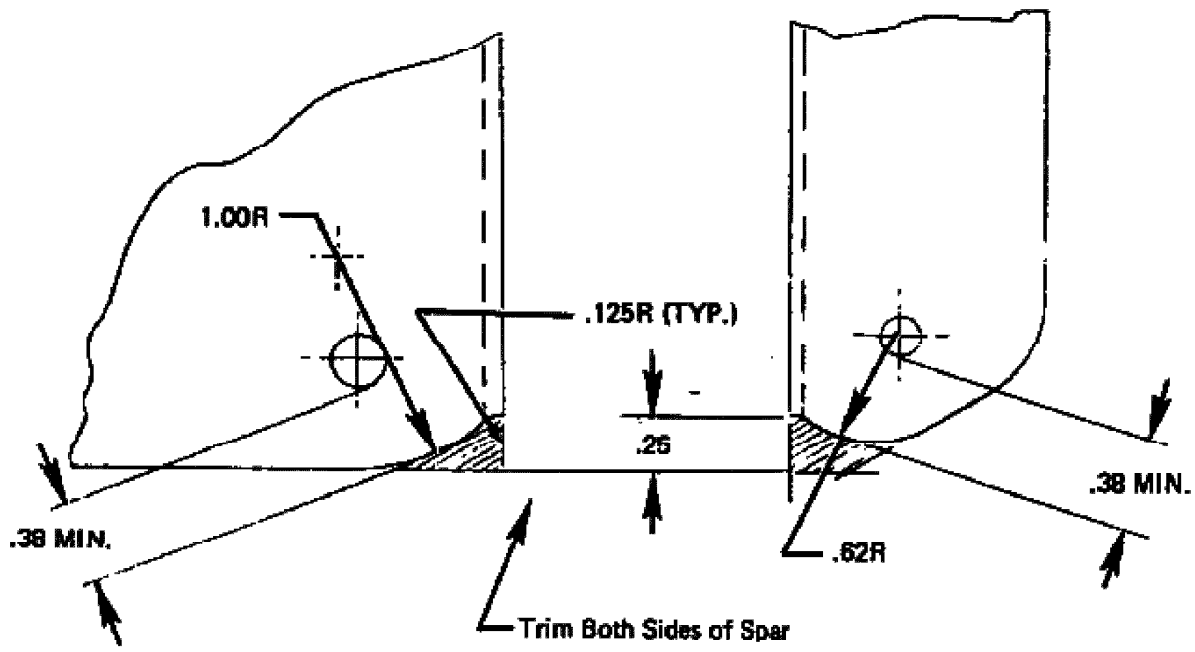

**FIGURE 2**  
**(SPAR TRIMMING DETAIL)**